

MCCREARY CONCRETE PRODUCTS, INC.
RUSHVILLE & CARMEL, INDIANA
765-932-3058 OR 317-844-5157

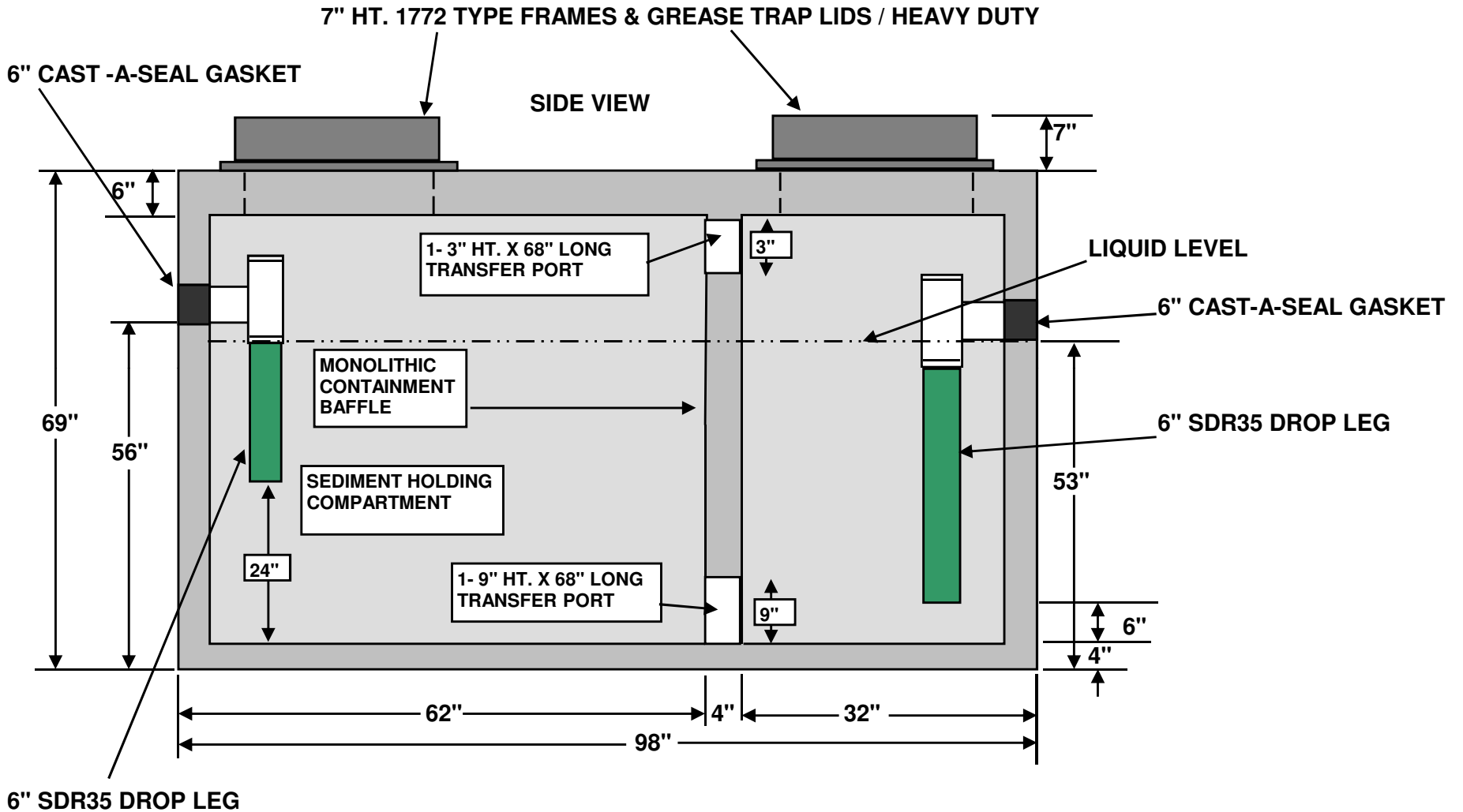

1000 GALLON COMMERCIAL GREASE/OIL/SEDIMENT
INTERCEPTOR H2O LOAD BEARING
2 - COMPARTMENT

"FORT WAYNE SPECIFICATION"



NOT TO SCALE

STRUCTURE WEIGHT 10854 LBS.

DCS51109

MCCREARY CONCRETE PRODUCTS, INC.
RUSHVILLE & CARMEL, INDIANA
765-932-3058 OR 317-844-5157



1000 GALLON COMMERCIAL GREASE/OIL/SEDIMENT
INTERCEPTOR H2O LOAD BEARING
2 - COMPARTMENT

"FORT WAYNE SPECIFICATION"

TOP VIEW

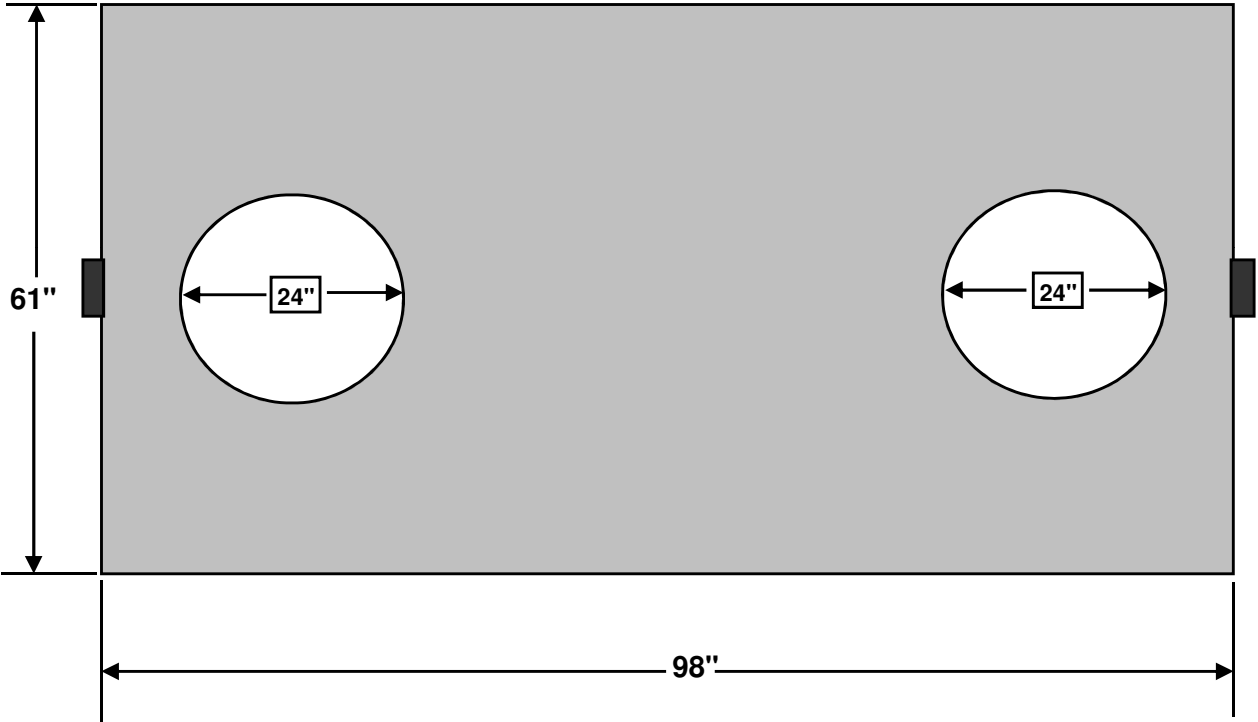

NOT TO SCALE

STRUCTURE WEIGHT 10854 LBS.

DCS51109