

MCCREARY CONCRETE PRODUCTS, INC.
RUSHVILLE & CARMEL, INDIANA
765-932-3058 OR 317-844-5157

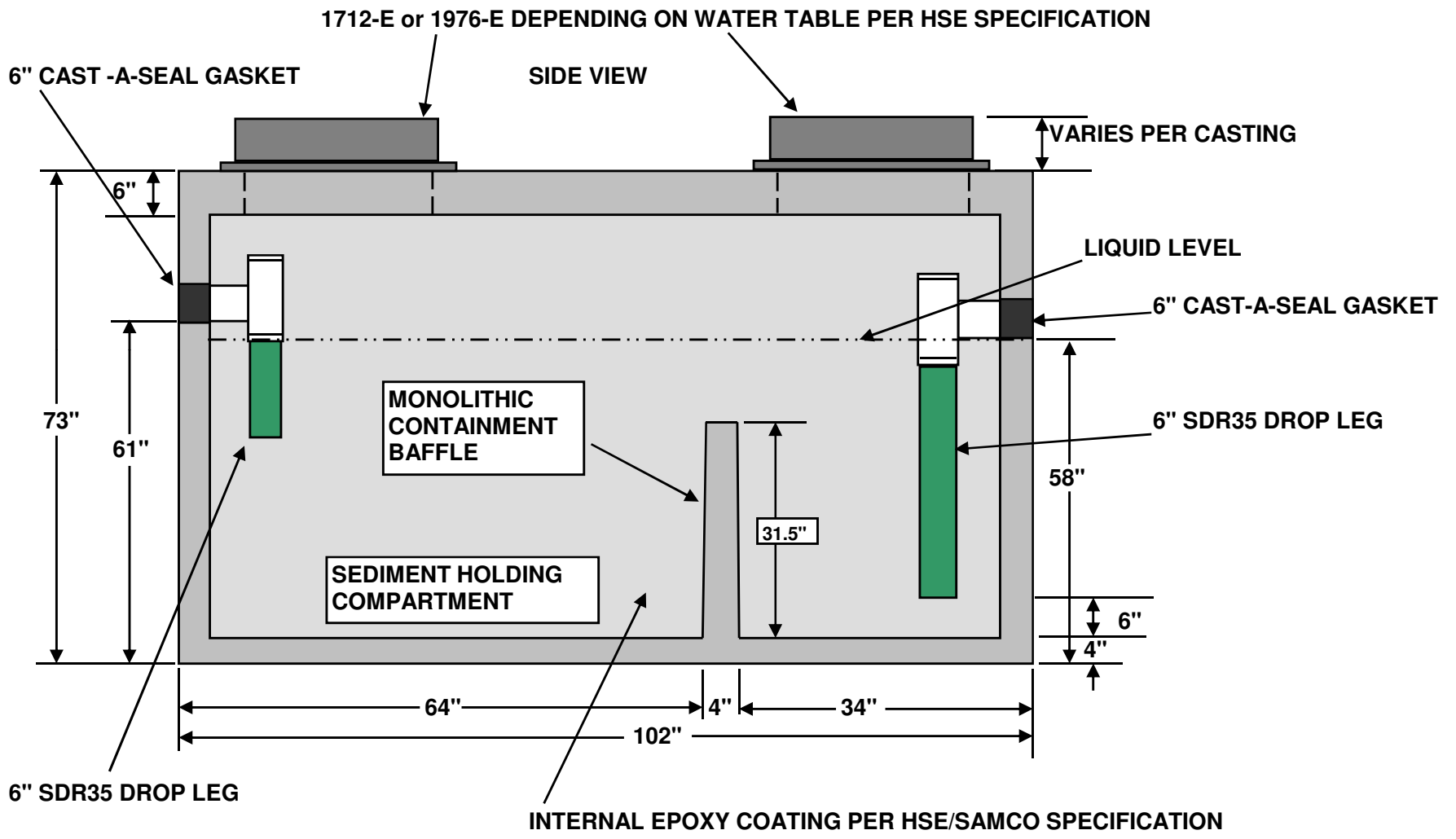

1250 GALLON COMMERCIAL GREASE/OIL/SEDIMENT
INTERCEPTOR H2O LOAD BEARING
HSE/SAMCO SPECIFICATION



NOT TO SCALE

STRUCTURE WEIGHT 12536 LBS.

DCS5109

MCCREARY CONCRETE PRODUCTS, INC.
RUSHVILLE & CARMEL, INDIANA
765-932-3058 OR 317-844-5157



1250 GALLON COMMERCIAL GREASE/OIL/SEDIMENT
INTERCEPTOR H2O LOAD BEARING
HSE/SAMCO SPECIFICATION

TOP VIEW

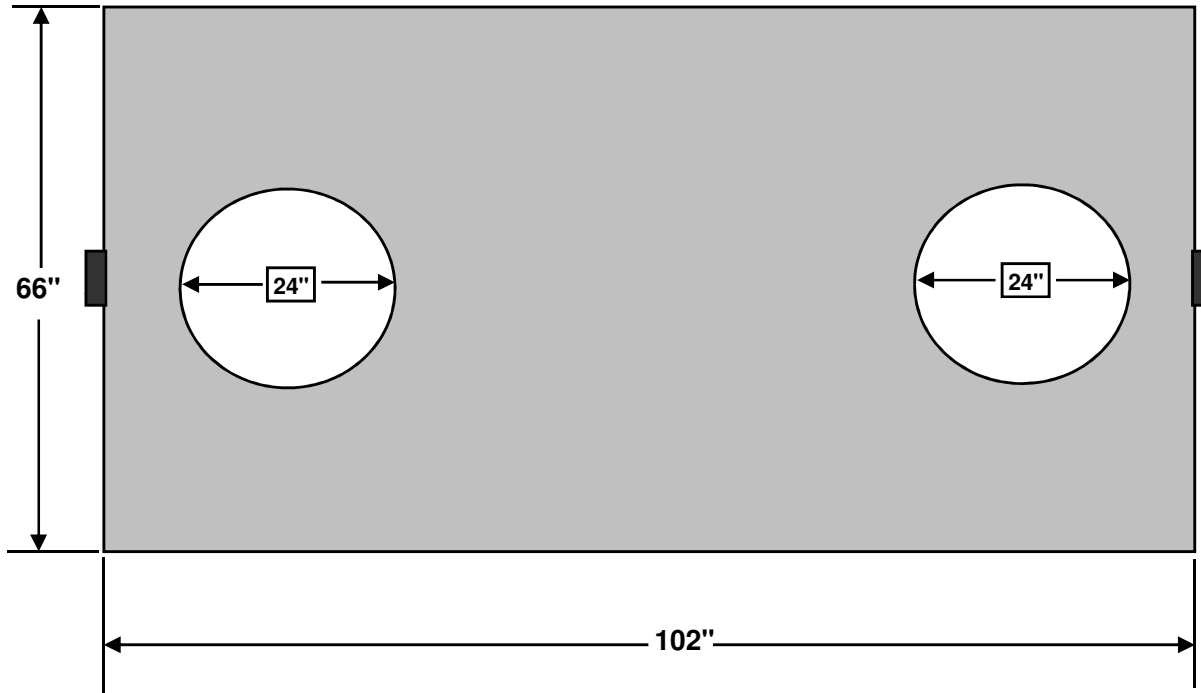

NOT TO SCALE

STRUCTURE WEIGHT 12536 LBS.

DCS5109

MCCREARY CONCRETE PRODUCTS, INC.
RUSHVILLE & CARMEL, INDIANA
765-932-3058 OR 317-844-5157



1250 GALLON COMMERCIAL GREASE/OIL/SEDIMENT
INTERCEPTOR H2O LOAD BEARING
HSE/SAMCO SPECIFICATION
TACO BELL

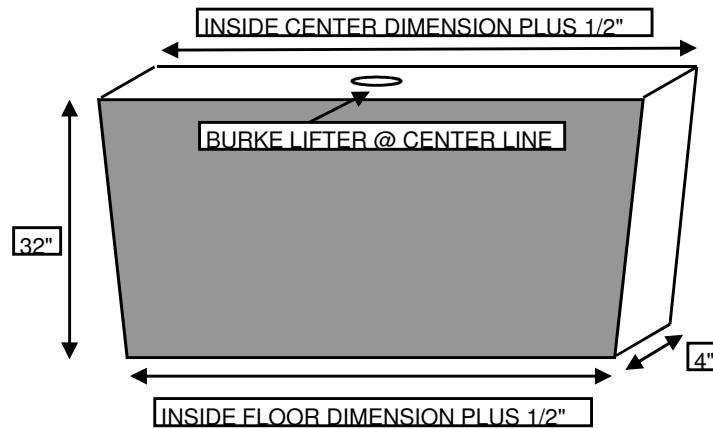
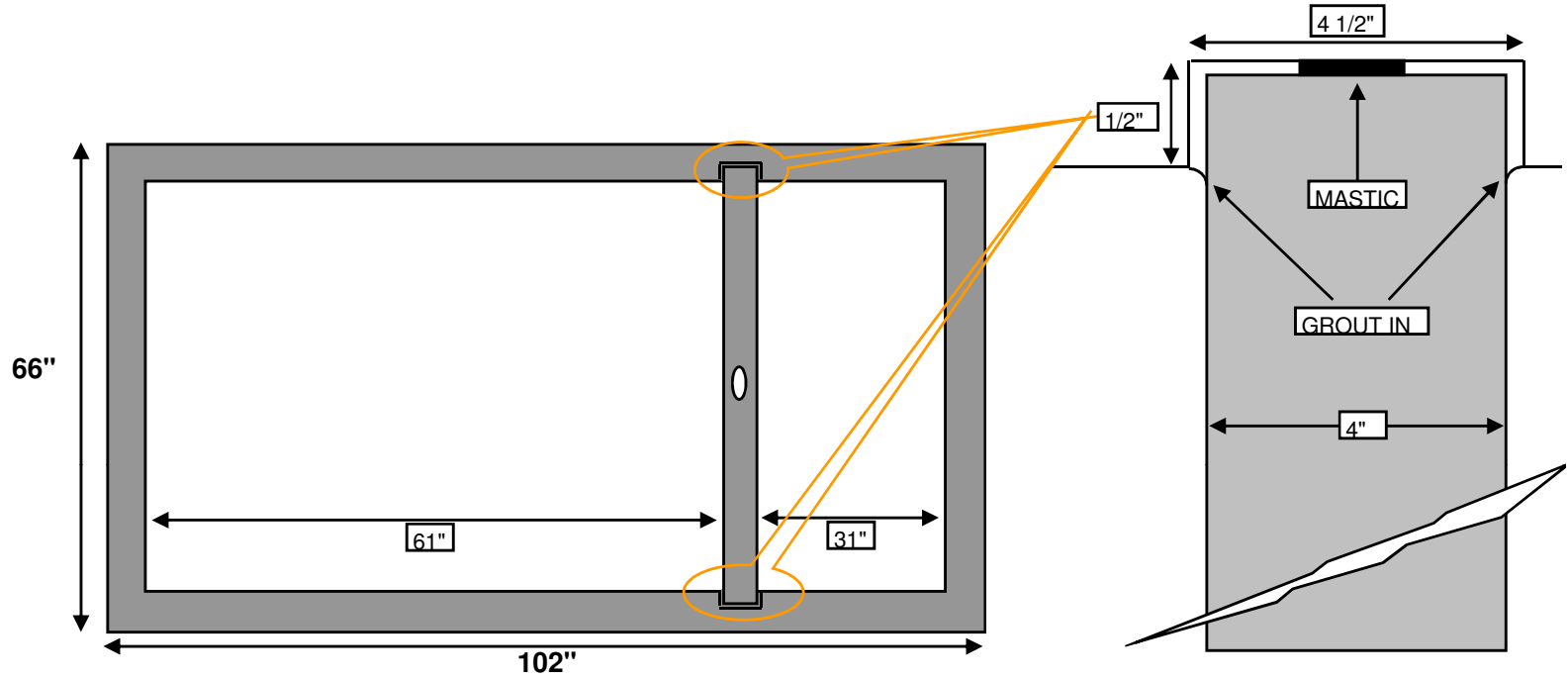

NOT TO SCALE

STRUCTURE WEIGHT 12536 LBS.

DCS5109