

MCCREARY CONCRETE PRODUCTS, INC.
RUSHVILLE AND CARMEL, INDIANA
765-932-3058 OR 317-844-5157

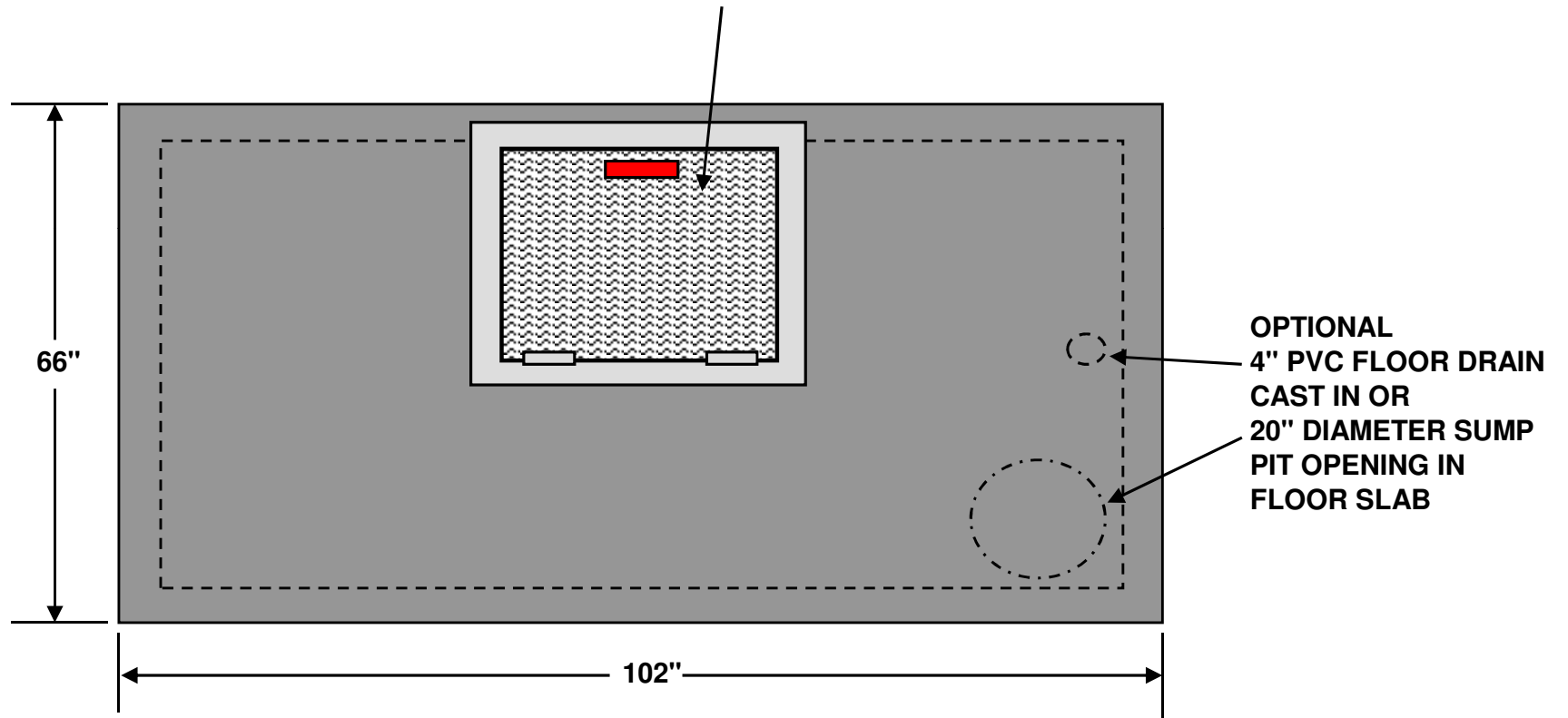

1250 COMMERCIAL METER VAULT

USF FABRICATION 30" X 30" ALUMINUM HATCH COVER, 300 PSF PEDESTRIAN LOADING, LOCK STAPLE, BITUMINOUS FRAME PAINT COATING, SLAMLOCK, RECESSED FLUSH DROP HANDLE, STAINLESS STEEL HARDWARE AND HINGES



TOP VIEW

NOT TO SCALE

STRUCTURE WEIGHT 9437 LBS.

RC2222008

MCCREARY CONCRETE PRODUCTS, INC.
RUSHVILLE AND CARMEL, INDIANA
765-932-3058 OR 317-844-5157



1250 COMMERCIAL METER VAULT

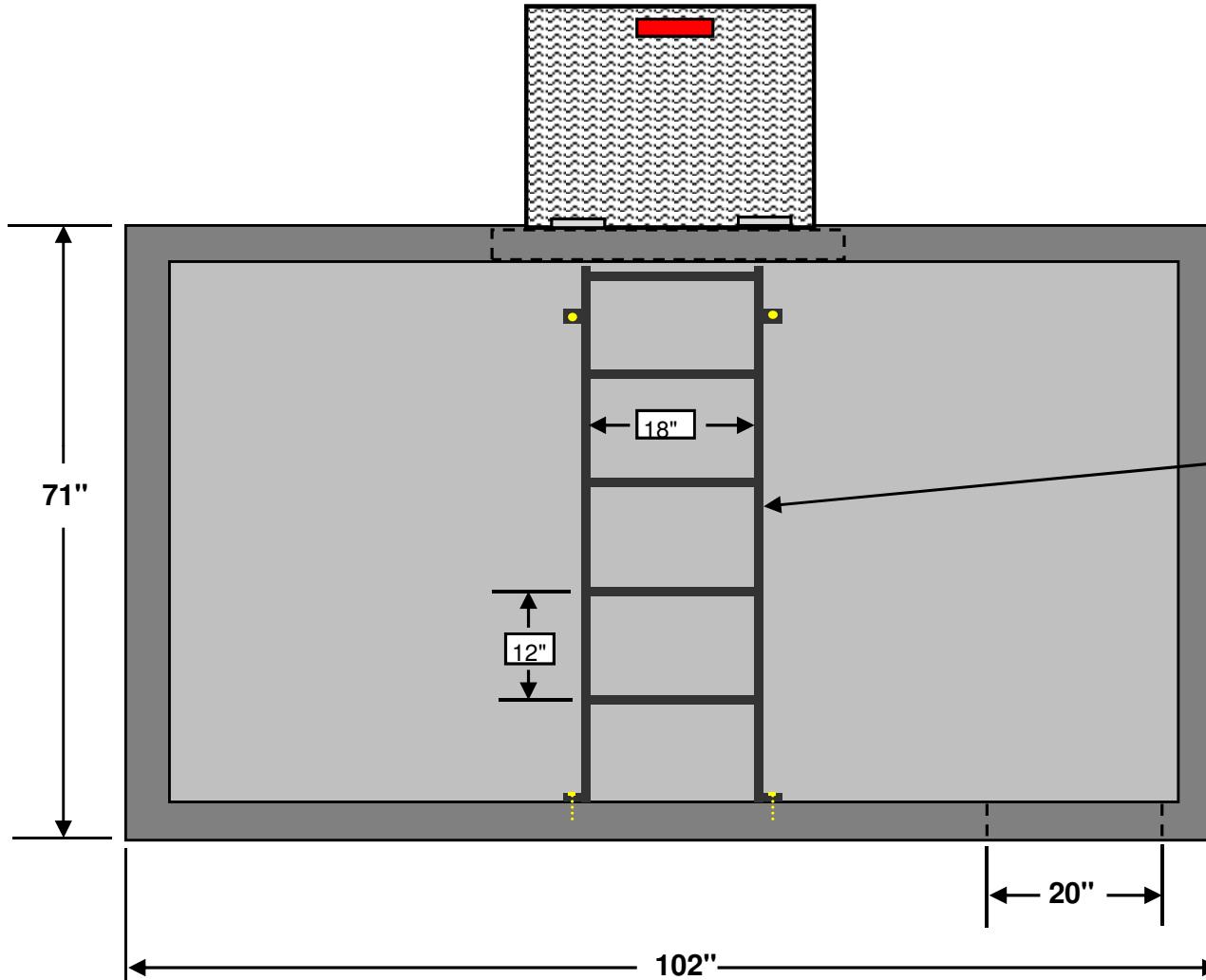

OSHA COMPLIANT
USF FABRICATION
ALUMINUM FLOOR /
WALL MOUNT
LADDER. STEPS ARE
18" WIDE AT 12" ON
CENTERS. LADDER
IS PREINSTALLED
USING STAINLESS
STEEL ANCHORS,
WASHERS AND NUTS.

SIDE VIEW CUT AWAY

NOT TO SCALE

STRUCTURE WEIGHT 9437 LBS.

RC2222008

MCCREARY CONCRETE PRODUCTS, INC.
RUSHVILLE AND CARMEL, INDIANA
765-932-3058 OR 317-844-5157



1250 COMMERCIAL METER VAULT

END VIEWS

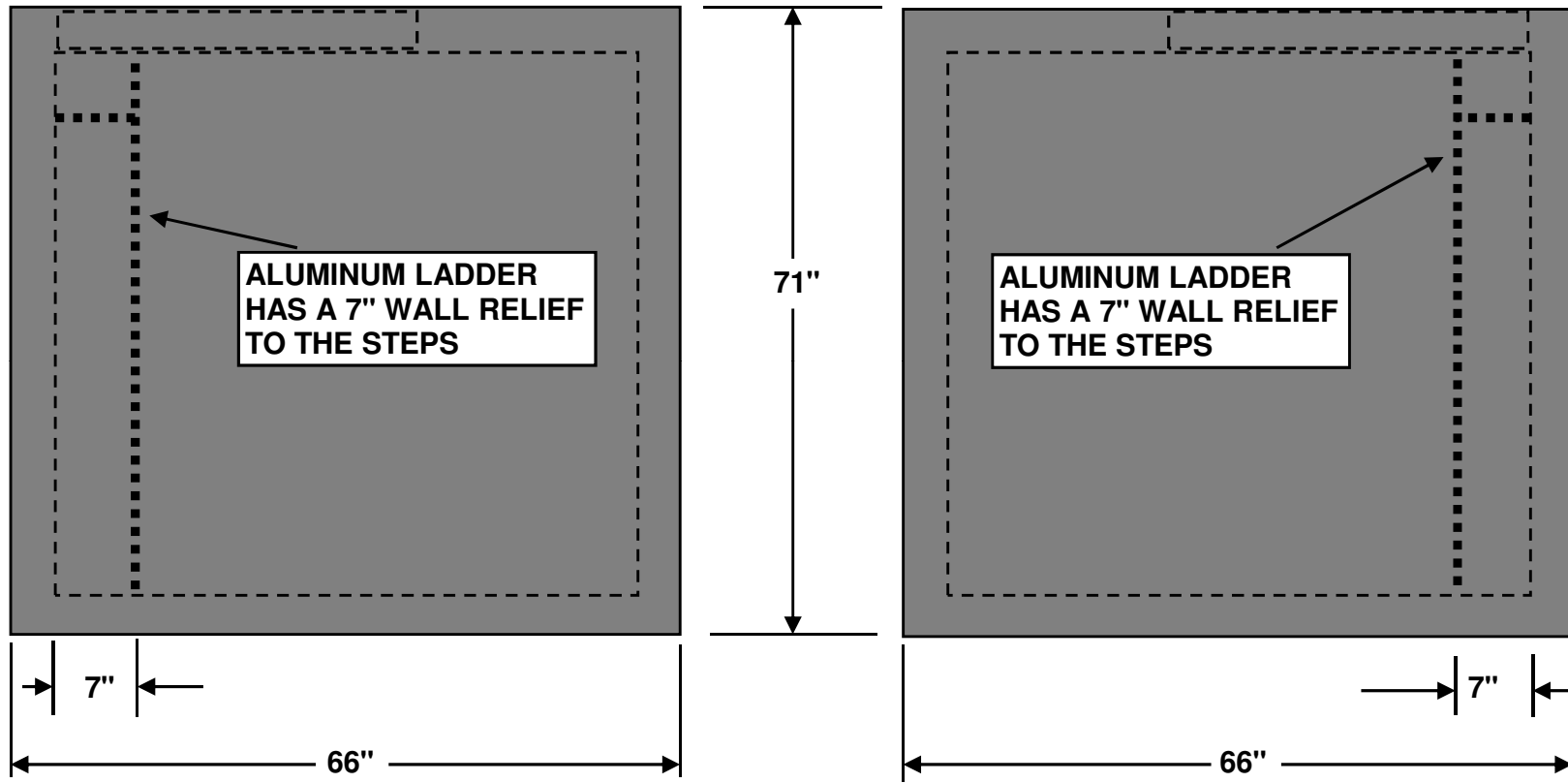

END OR SIDEWALL OPENINGS CAN BE CORED PRIOR TO SHIPMENT FOR AN ADDITIONAL CHARGE. H2O LOAD BEARING TOPS, GRADE ADJUSTING RINGS, LARGER HATCH COVERS AND OTHER MODIFICATIONS CAN BE MADE PER JOB REQUIREMENTS.

NOT TO SCALE

STRUCTURE WEIGHT 9437 LBS.

RC2222008