

MCCREARY CONCRETE PRODUCTS, INC.
 RUSHVILLE AND CARMEL, INDIANA
 765-932-3058 OR 317-844-5157

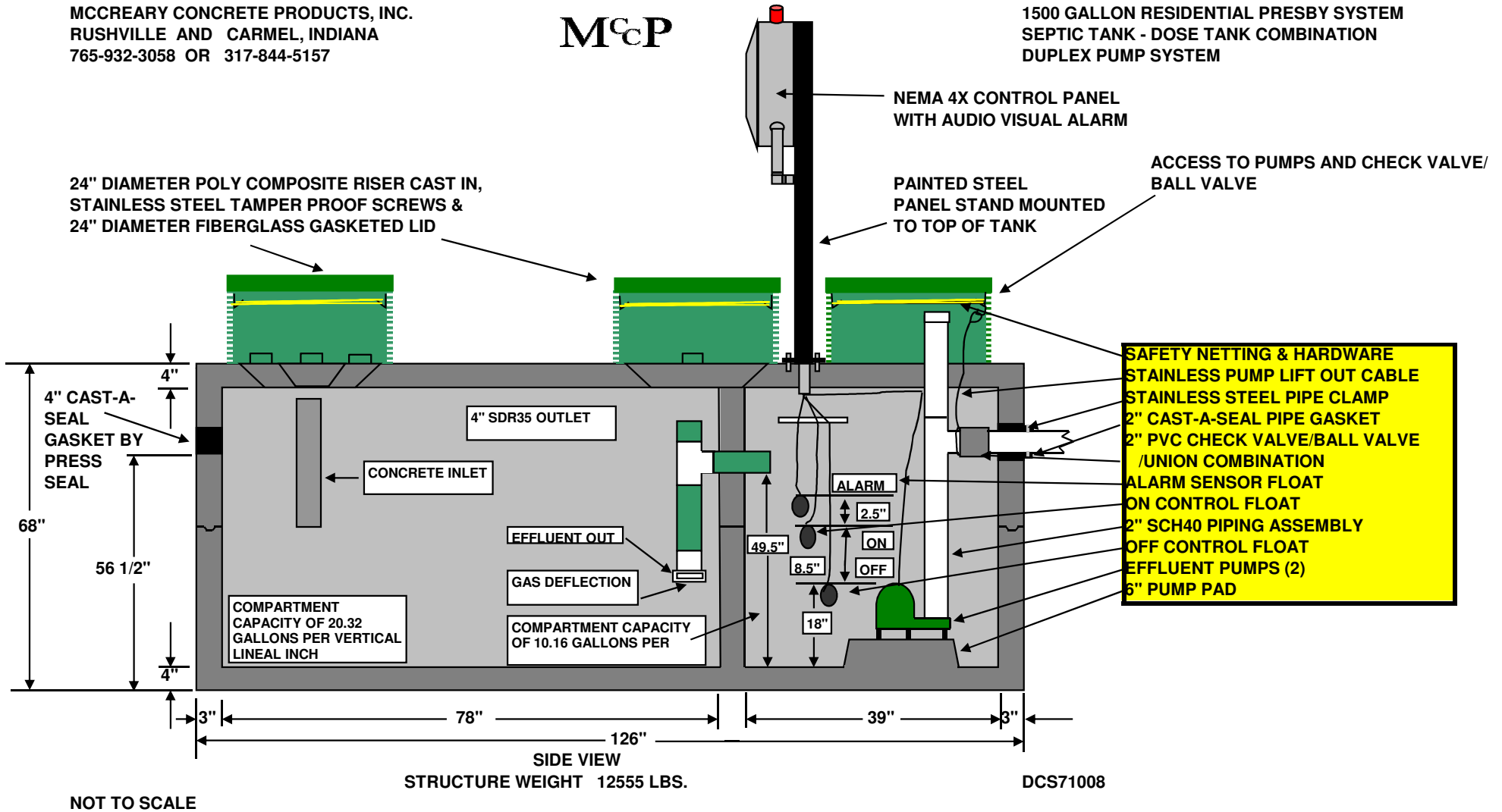

1500 GALLON RESIDENTIAL PRESBY SYSTEM
 SEPTIC TANK - DOSE TANK COMBINATION
 DUPLEX PUMP SYSTEM



MCCREARY CONCRETE PRODUCTS, INC.
RUSHVILLE AND CARMEL, INDIANA
765-932-3058 OR 317-844-5157



1500 GALLON RESIDENTIAL PRESBY SYSTEM
SEPTIC TANK - DOSE TANK COMBINATION
DUPLEX PUMP SYSTEM

TOP VIEW

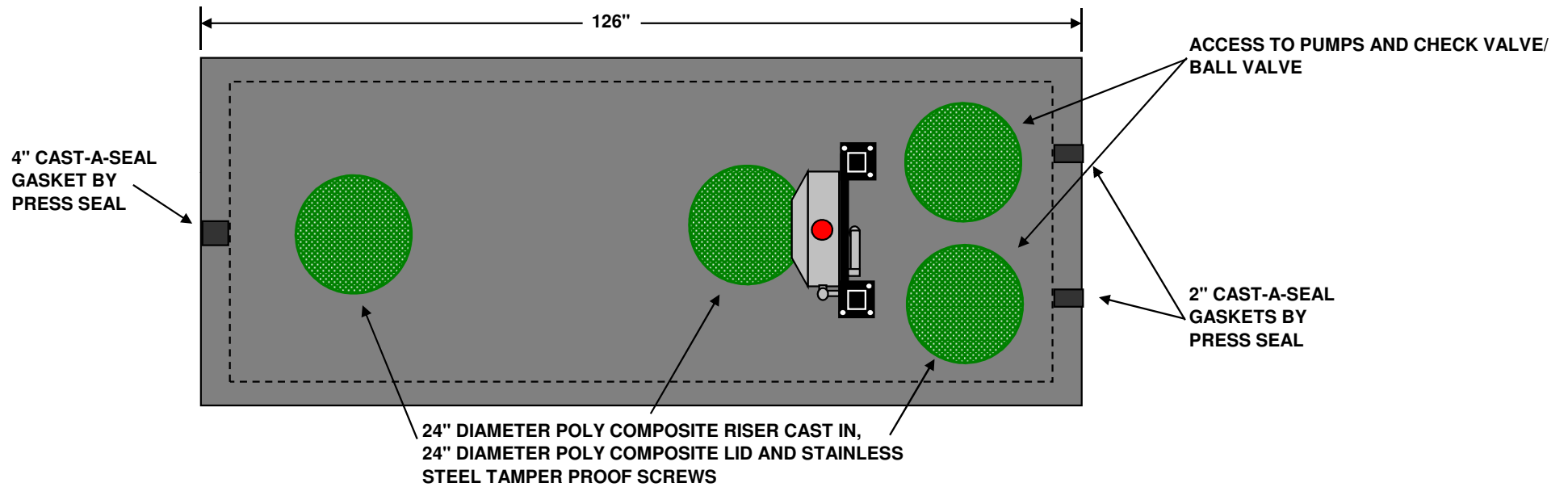

NOT TO SCALE

STRUCTURE WEIGHT 12555 LBS.

DCS71008

MCCREARY CONCRETE PRODUCTS, INC.
RUSHVILLE AND CARMEL, INDIANA
765-932-3058 OR 317-844-5157



1500 GALLON RESIDENTIAL PRESBY SYSTEM
SEPTIC TANK - DOSE TANK COMBINATION
DUPLEX PUMP SYSTEM

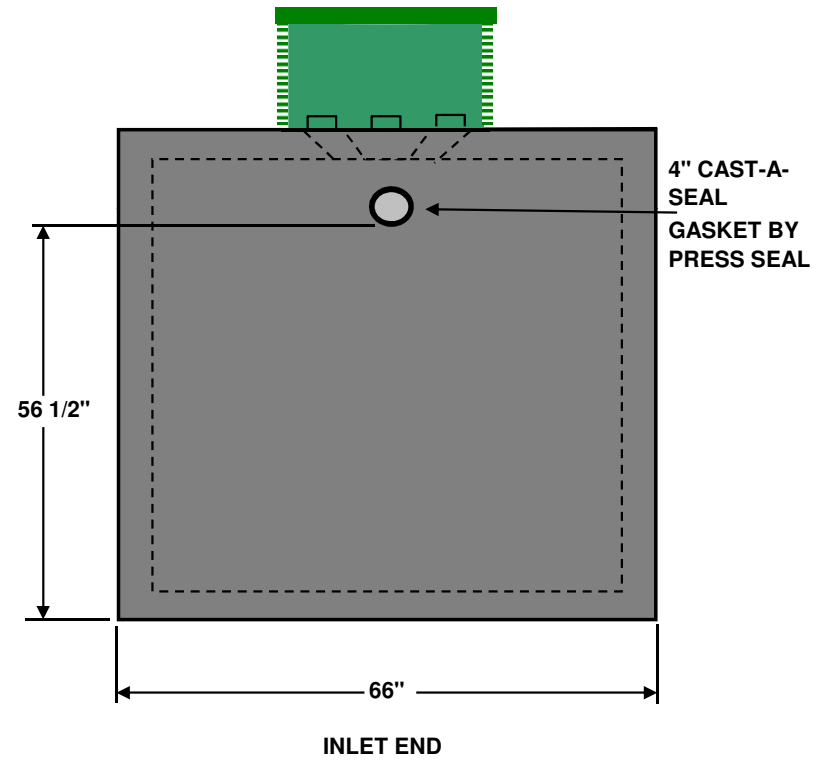
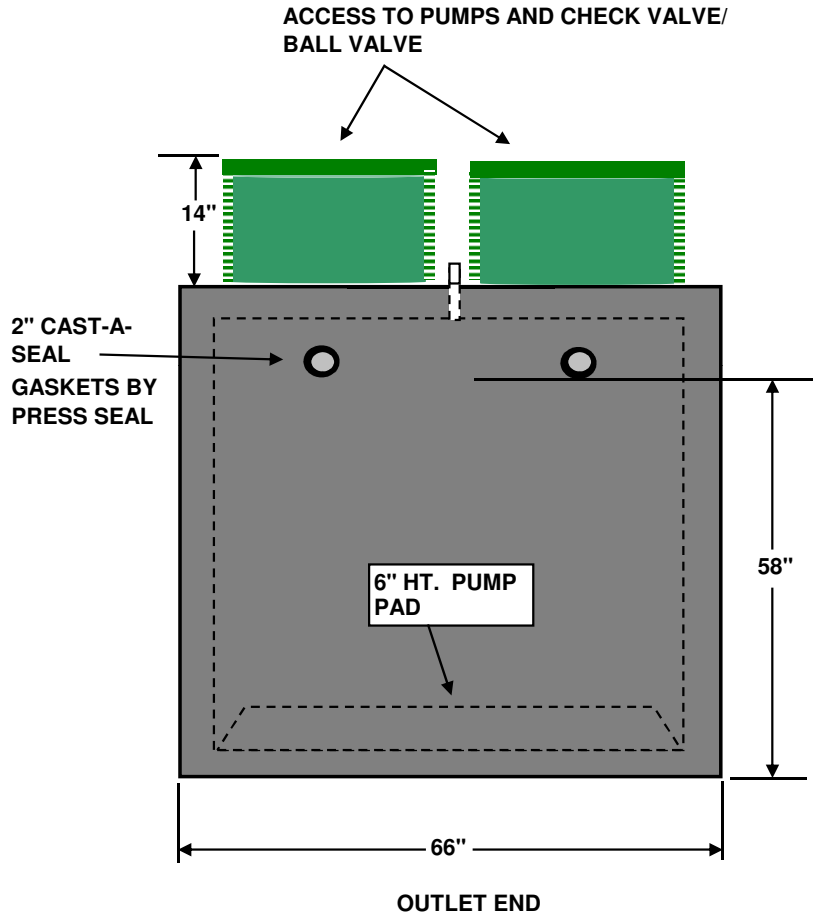

NOT TO SCALE

STRUCTURE WEIGHT 12555 LBS.

DCS71008