

MCCREARY CONCRETE PRODUCTS, INC.
 RUSHVILLE AND CARMEL, INDIANA
 765-932-3058 OR 317-844-5157

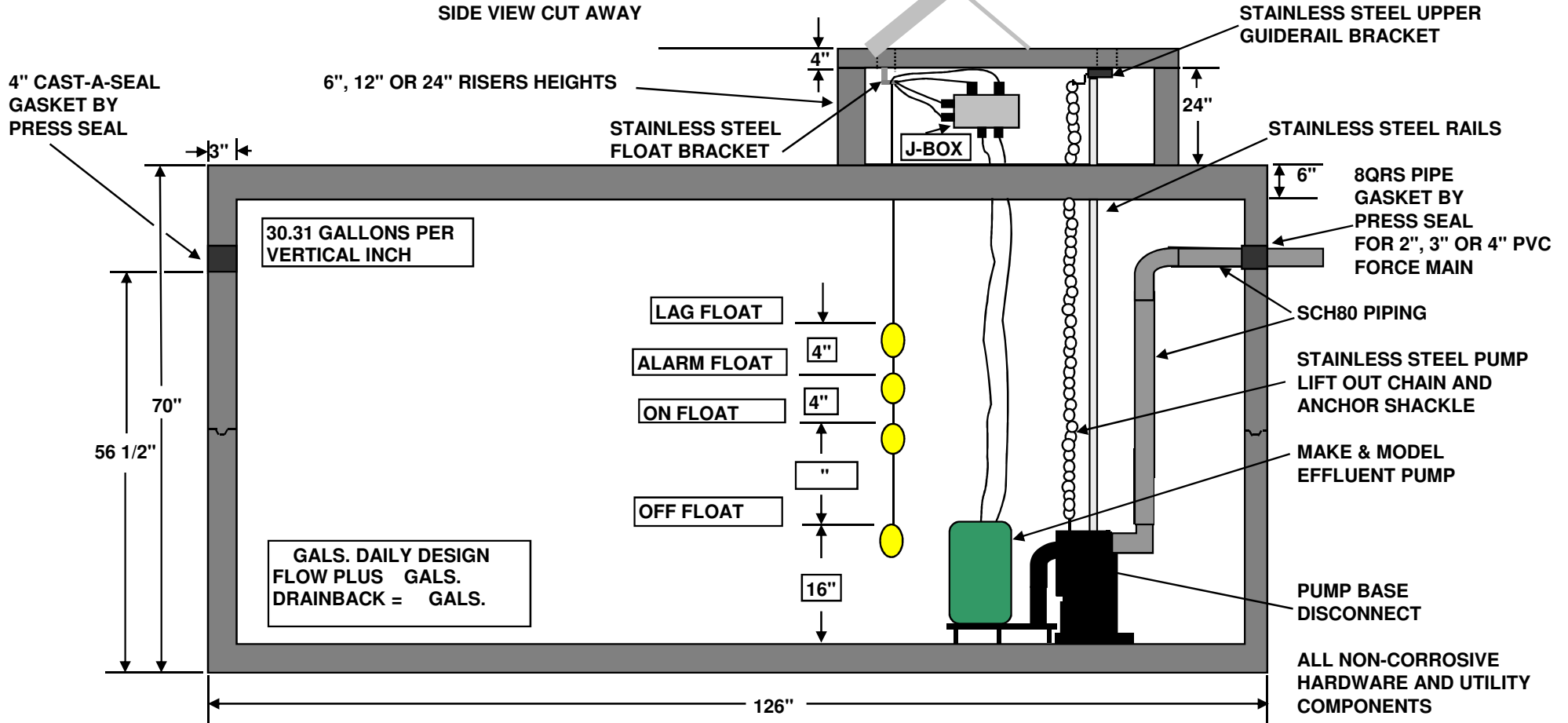

1500 GALLON DUPLEX COMMERCIAL LIFT STATION
 H2O LOAD BEARING

SIDE VIEW CUT AWAY



30.31 GALLONS PER VERTICAL INCH

GALS. DAILY DESIGN FLOW PLUS GALS. DRAINBACK = GALS.

NOT TO SCALE

STRUCTURE WEIGHT 13041 LBS.

RC2252008

MCCREARY CONCRETE PRODUCTS, INC.
RUSHVILLE AND CARMEL, INDIANA
765-932-3058 OR 317-844-5157



1500 GALLON DUPLEX COMMERCIAL LIFT STATION
H2O LOAD BEARING

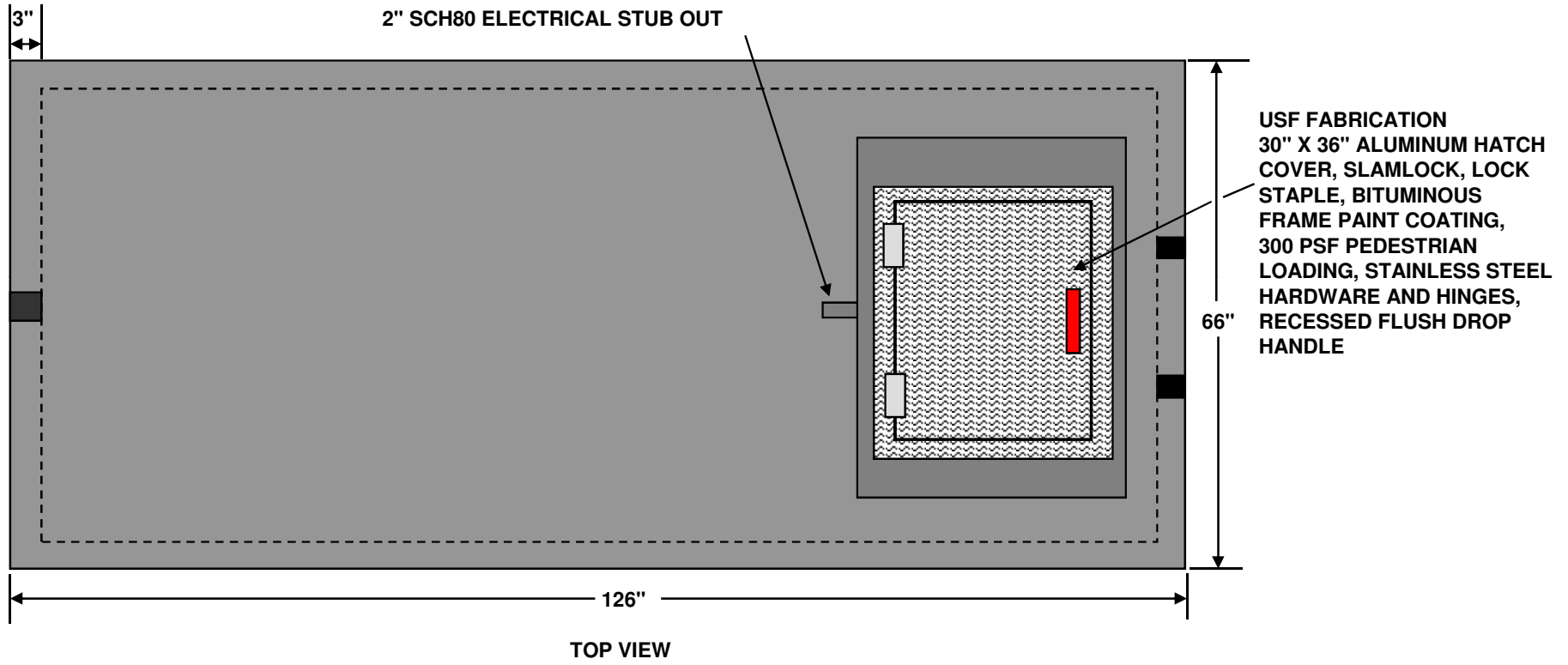

NOT TO SCALE

STRUCTURE WEIGHT 13041 LBS.

RC2252008

MCCREARY CONCRETE PRODUCTS, INC.
RUSHVILLE AND CARMEL, INDIANA
765-932-3058 OR 317-844-5157



1500 GALLON DUPLEX COMMERCIAL LIFT STATION
H2O LOAD BEARING

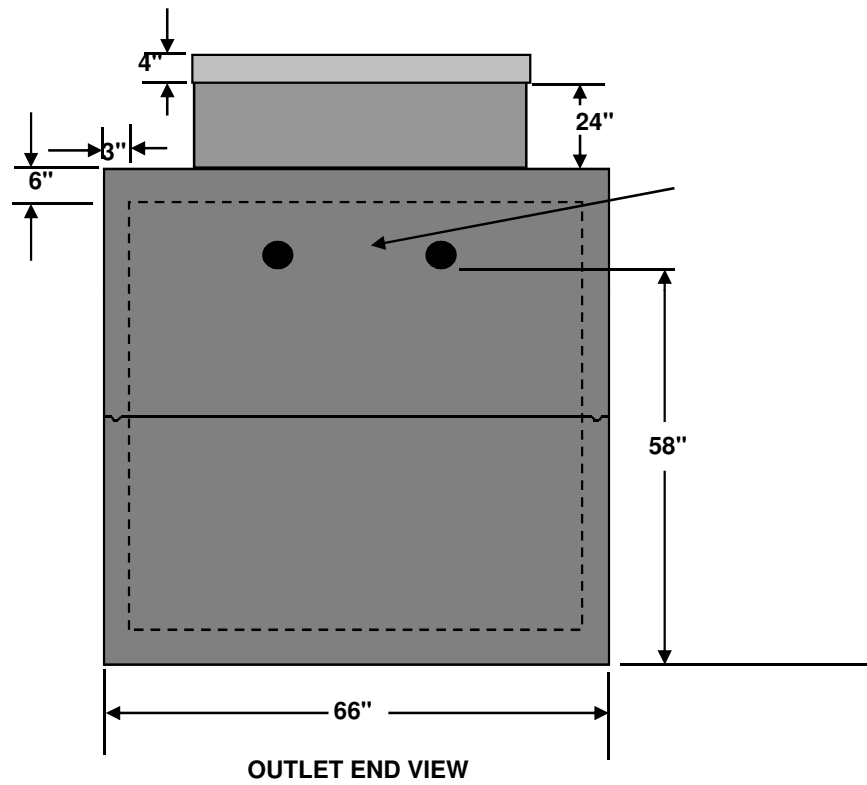

CORE AND SEAL
8QRS PIPE GASKET
BY PRESS SEAL
FOR 2", 3" OR 4"
PVC FORCE MAIN
DUAL OR SINGLE
DISCHARGE
(GASKET ELEVATION
CAN BE MODIFIED
UPON REQUEST)

4", 6" OR 8" PIPE
GASKET BY
PRESS SEAL
CAST IN OR
CORE AND SEAL

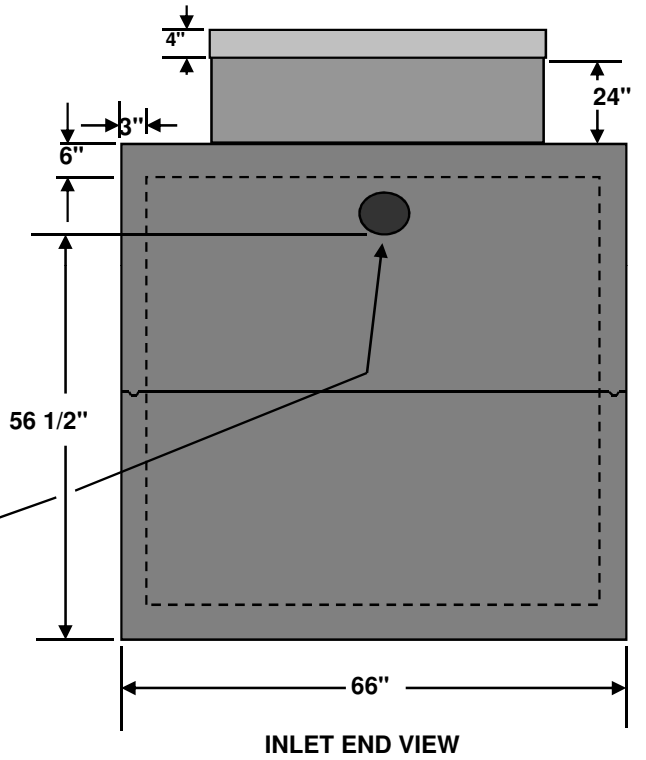

NOT TO SCALE

STRUCTURE WEIGHT 13041 LBS.

RC2252008