

4" TOP CAP WITH CAST IN 30" X 36" ALUMINUM HATCH COVER
300 PSF PEDESTRIAN LOADING, SLAMLOCK, STAINLESS HINGES
& HARDWARE, BITUMINOUS FRAME PAINT COATING, LOCK STAPLE,
RECESSED FLUSH DROP HANDLE

6", 12" OR 24" RISERS HEIGHTS

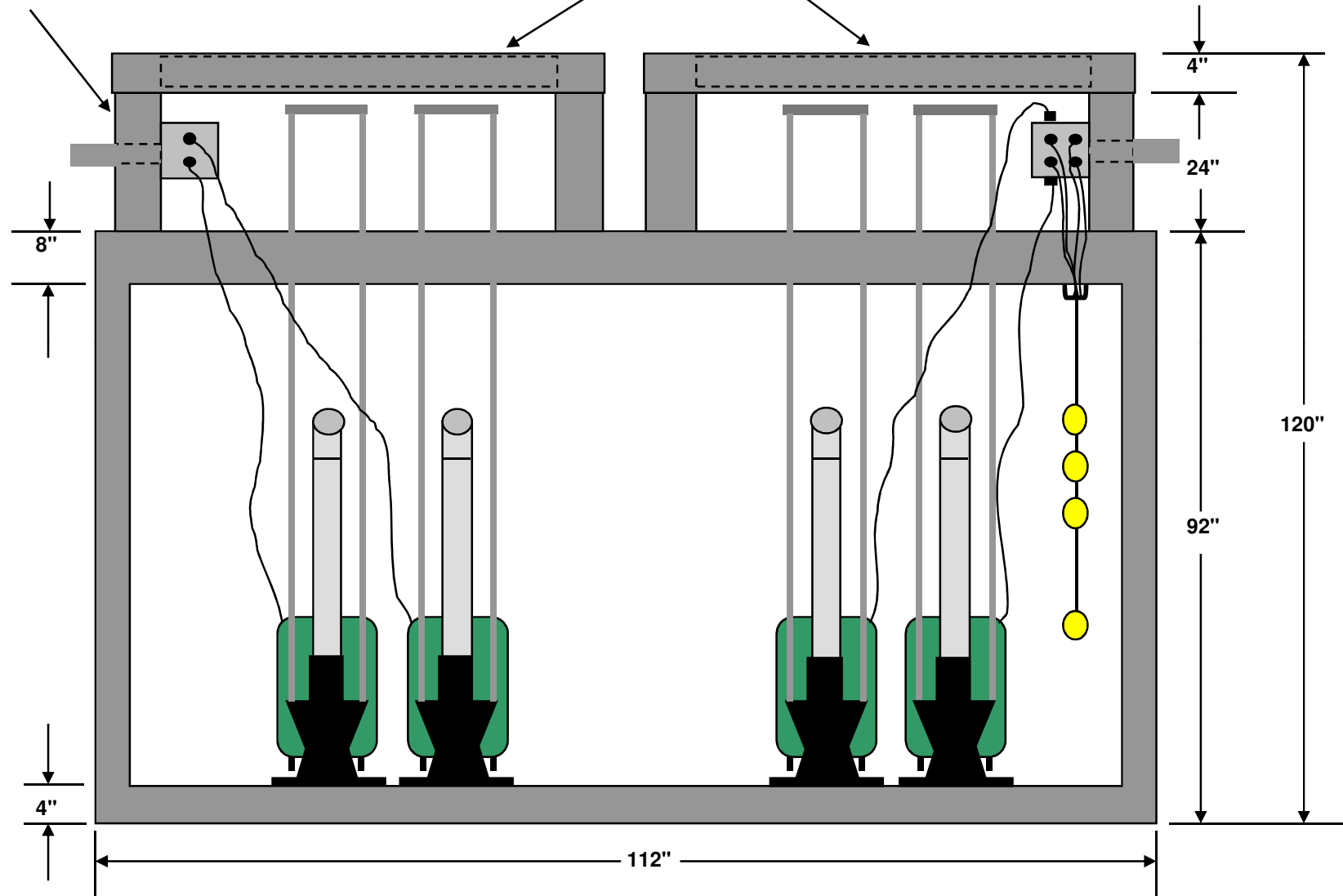

SIDE VIEW CUT AWAY

MCCREARY CONCRETE PRODUCTS, INC.
 RUSHVILLE AND CARMEL, INDIANA
 765-932-3058 OR 317-844-5157



2000 GALLON COMMERCIAL QUADRAPLEX LIFT STATION
 H2O LOAD BEARING

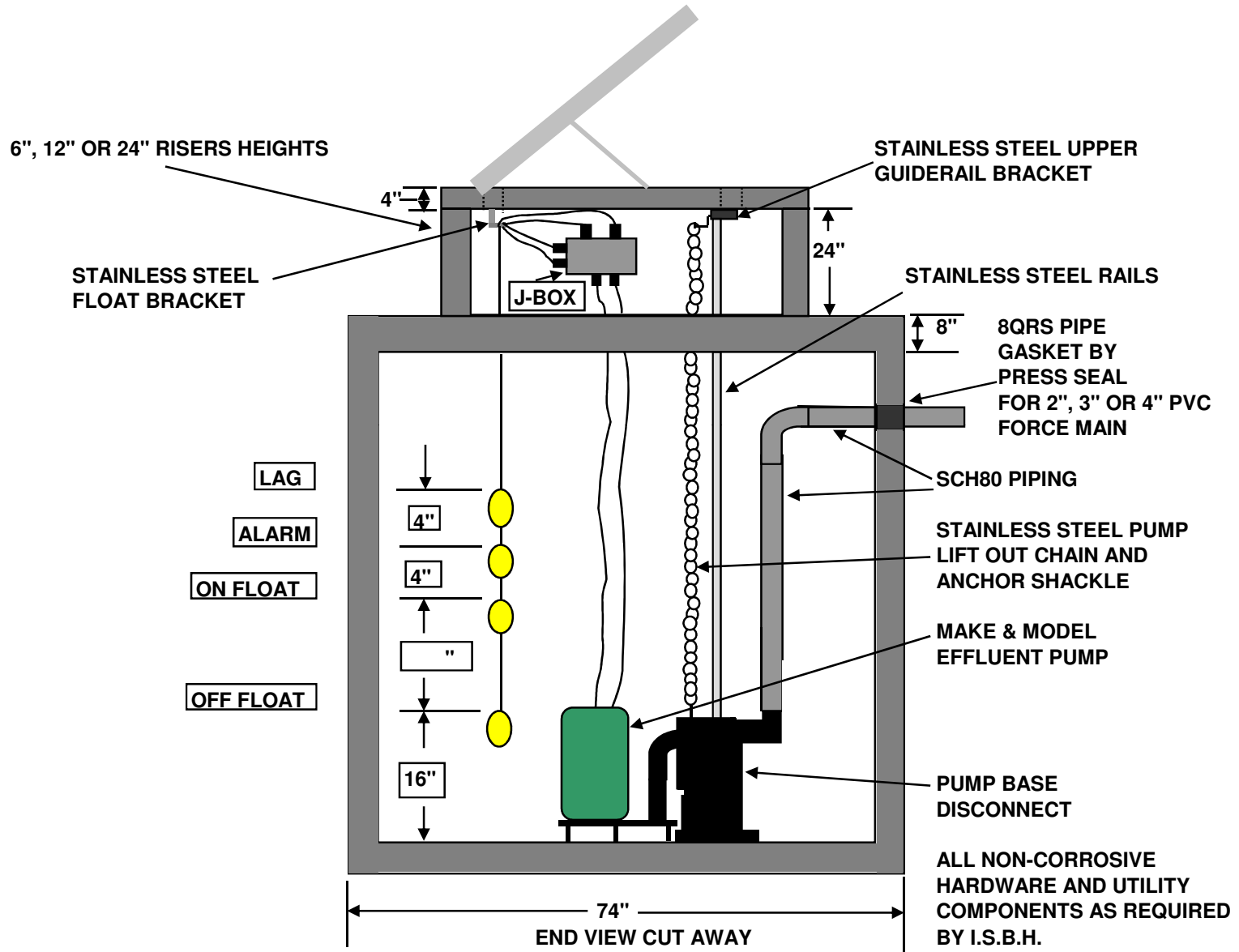

NOT TO SCALE

STRUCTURE WEIGHT 16760 LBS.

RC2202008

MCCREARY CONCRETE PRODUCTS, INC.
RUSHVILLE AND CARMEL, INDIANA
765-932-3058 OR 317-844-5157



2000 GALLON COMMERCIAL QUADRAPLEX LIFT STATION
H2O LOAD BEARING

USF FABRICATION 30" X 36" ALUMINUM HATCH COVER,
SLAMLOCK, BITUMINOUS FRAME PAINT COATING, LOCK
STAPLE, 300 PSF PEDESTRIAN LOADING, STAINLESS
STEEL HARDWARE AND HINGES, RECESSED FLUSH
DROP HANDLE

2" SCH80 ELECTRICAL STUB OUT

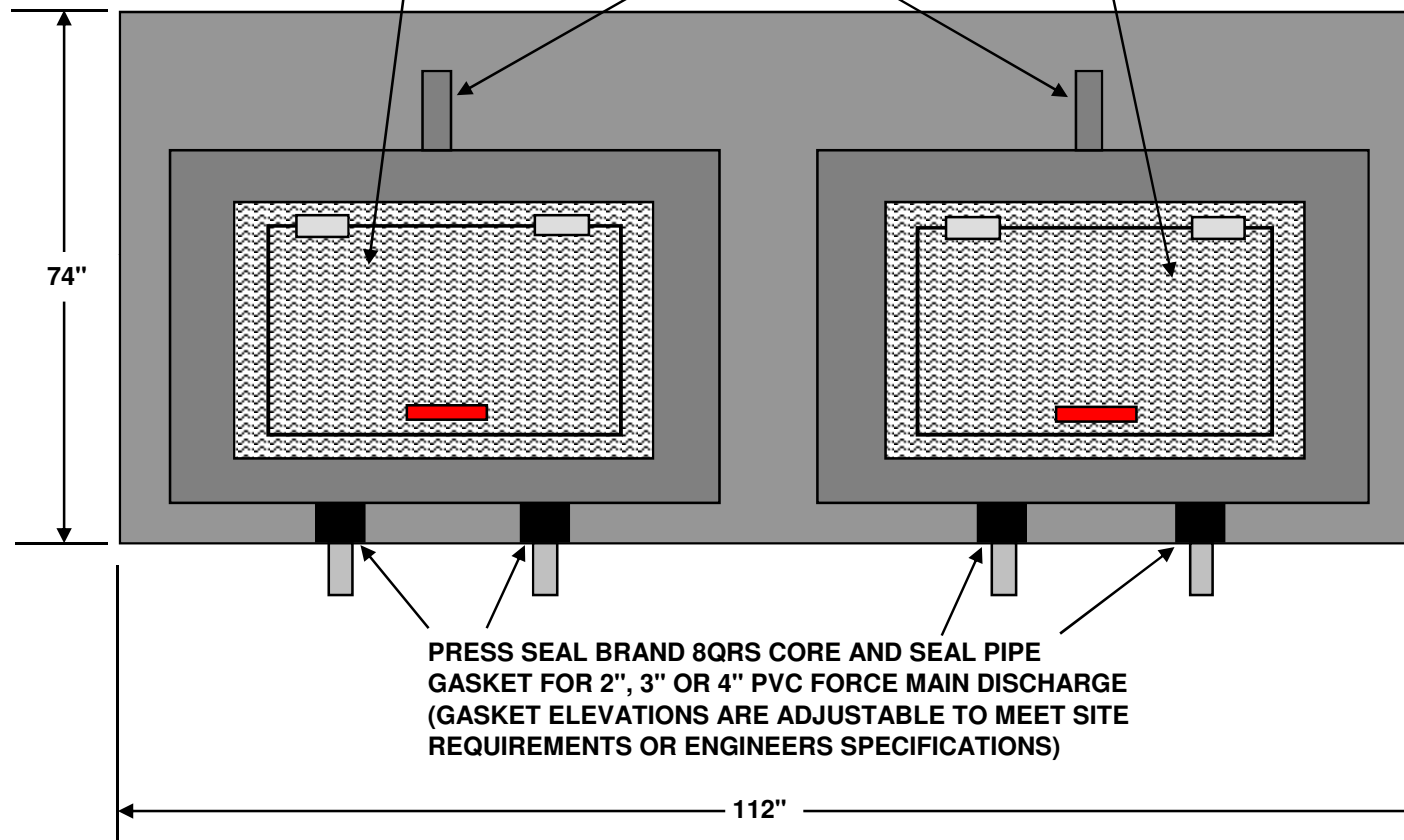

PRESS SEAL BRAND 8QRS CORE AND SEAL PIPE
GASKET FOR 2", 3" OR 4" PVC FORCE MAIN DISCHARGE
(GASKET ELEVATIONS ARE ADJUSTABLE TO MEET SITE
REQUIREMENTS OR ENGINEERS SPECIFICATIONS)

TOP VIEW

NOT TO SCALE

STRUCTURE WEIGHT 16760 LBS.

RC2202008

MCCREARY CONCRETE PRODUCTS, INC.
RUSHVILLE AND CARMEL, INDIANA
765-932-3058 OR 317-844-5157



2000 GALLON COMMERCIAL QUADRAPLEX LIFT STATION
H2O LOAD BEARING

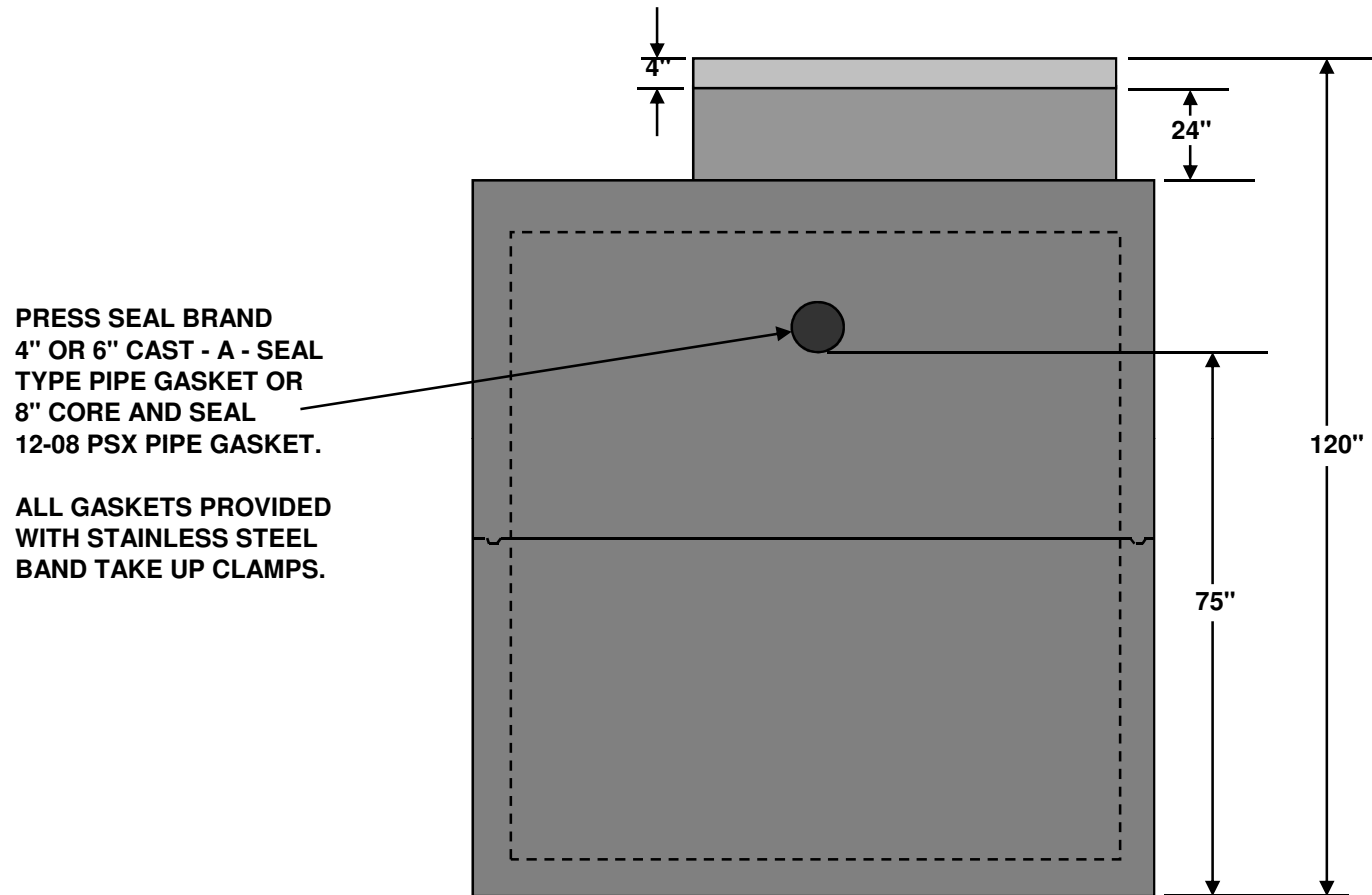

INLET END VIEW

NOT TO SCALE

STRUCTURE WEIGHT 16760 LBS.

RC2202008