

MCCREARY CONCRETE PRODUCTS, INC.  
 RUSHVILLE AND CARMEL, INDIANA  
 765-932-3058 OR 317-844-5157



2000 GALLON SIMPLEX COMMERCIAL LIFT STATION  
 H2O LOAD BEARING

SIDE VIEW CUT AWAY

4" CAST-A-SEAL  
 GASKET BY  
 PRESS SEAL

6", 12" OR 24" RISERS HEIGHTS

STAINLESS STEEL  
 FLOAT BRACKET

J-BOX

STAINLESS STEEL UPPER  
 GUIDERAIL BRACKET

STAINLESS STEEL RAILS

8QRS PIPE  
 GASKET BY  
 PRESS SEAL  
 FOR 2", 3" OR 4" PVC  
 FORCE MAIN

SCH80 PIPING

STAINLESS STEEL PUMP  
 LIFT OUT CHAIN AND  
 ANCHOR SHACKLE

MAKE & MODEL  
 EFFLUENT PUMP

PUMP BASE  
 DISCONNECT

ALL NON-CORROSIVE  
 HARDWARE AND UTILITY  
 COMPONENTS

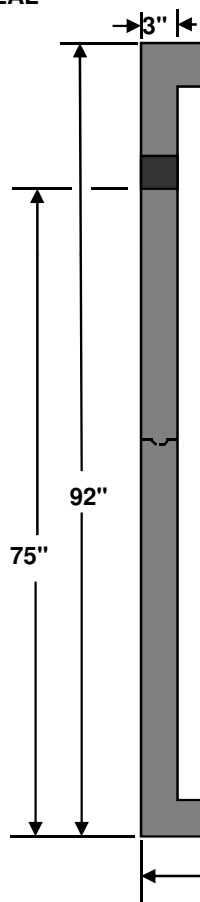

31.21 GALLONS PER  
 VERTICAL INCH

388 GALS. DAILY DESIGN  
 FLOW PLUS 125 GALS.  
 DRAINBACK = 513 GALS.

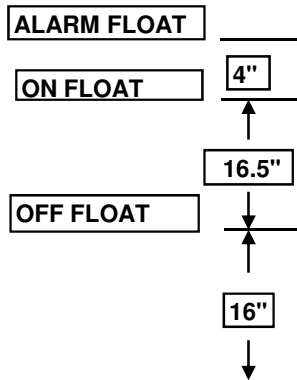

112"

NOT TO SCALE

STRUCTURE WEIGHT 16760 LBS.

RC10022008

MCCREARY CONCRETE PRODUCTS, INC.  
RUSHVILLE AND CARMEL, INDIANA  
765-932-3058 OR 317-844-5157



2000 GALLON DUPLEX COMMERCIAL LIFT STATION  
H2O LOAD BEARING

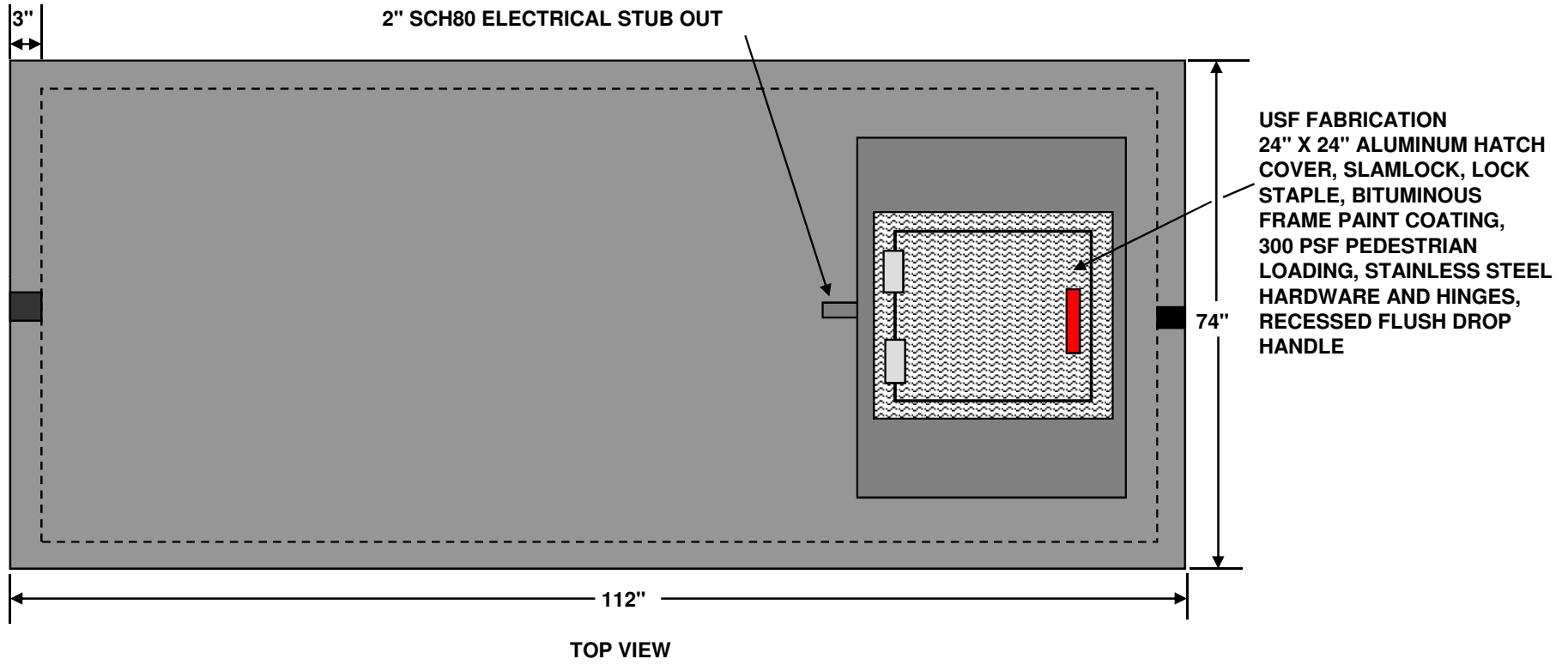

NOT TO SCALE

STRUCTURE WEIGHT 16760 LBS.

RC10022008

MCCREARY CONCRETE PRODUCTS, INC.  
RUSHVILLE AND CARMEL, INDIANA  
765-932-3058 OR 317-844-5157



2000 GALLON SIMPLEX COMMERCIAL LIFT STATION  
H2O LOAD BEARING

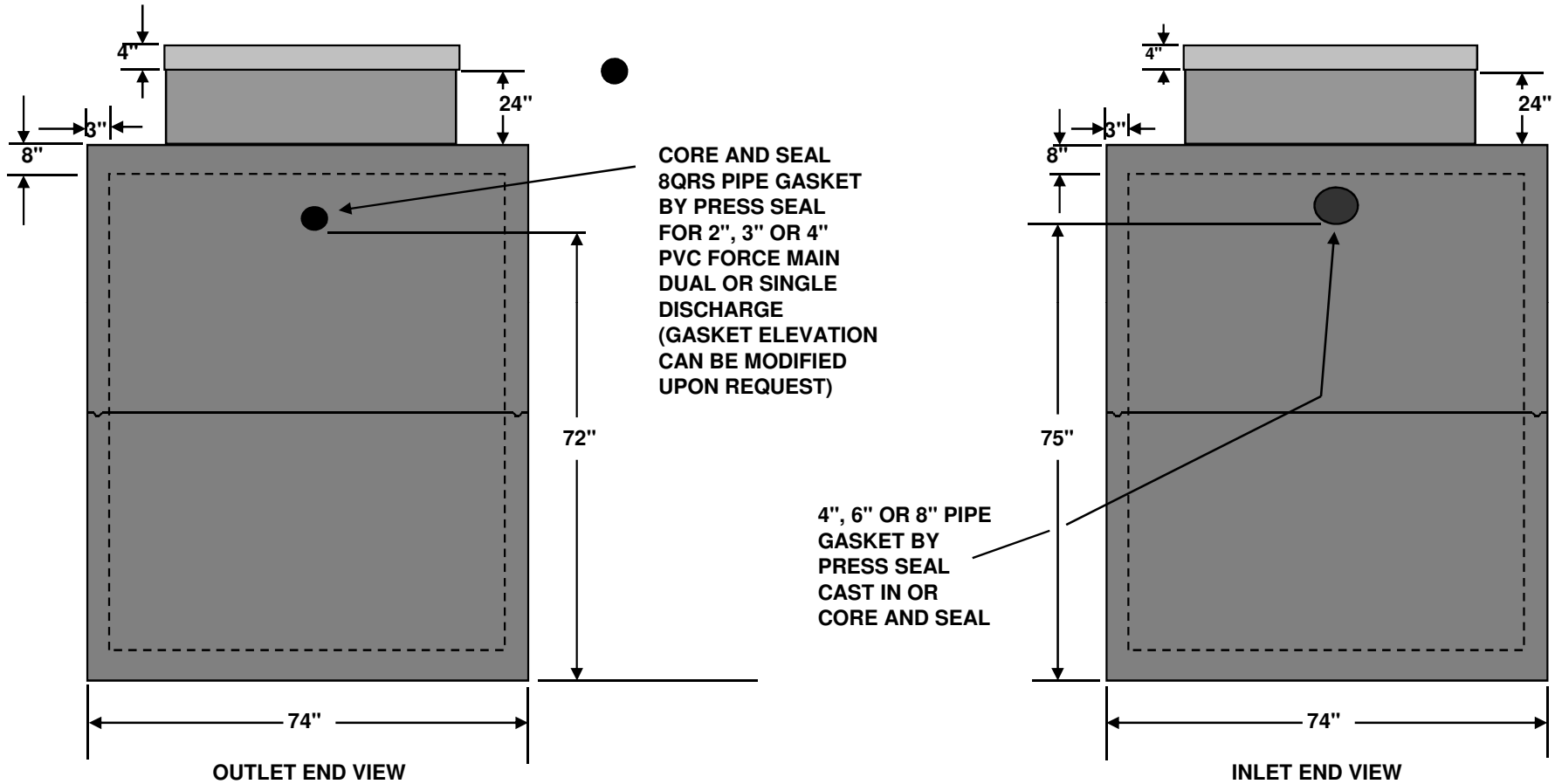

NOT TO SCALE

STRUCTURE WEIGHT 16760 LBS.

RC10022008