

SIDE VIEW CUT AWAY

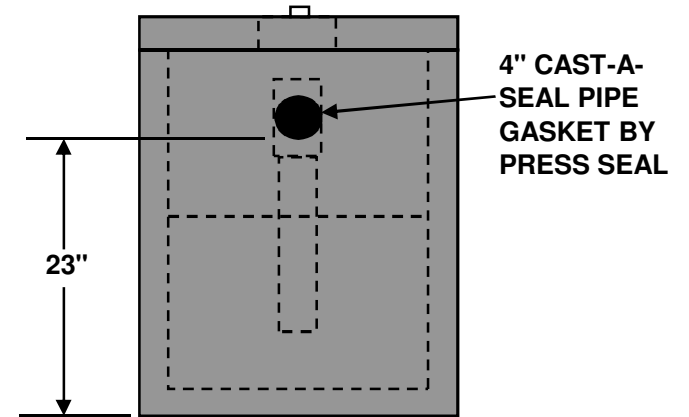

OUTLET  
 END VIEW

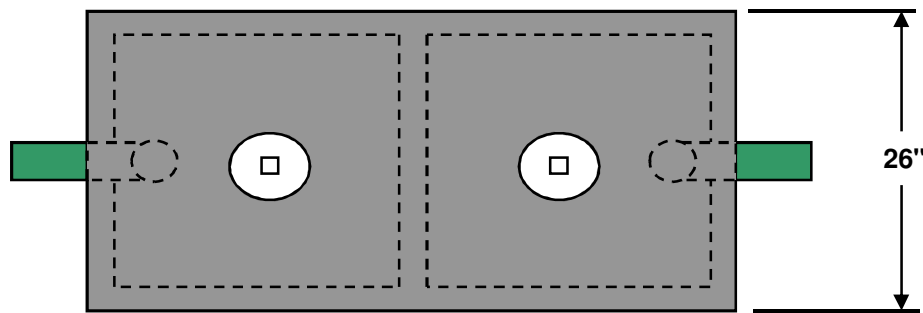

TOP VIEW

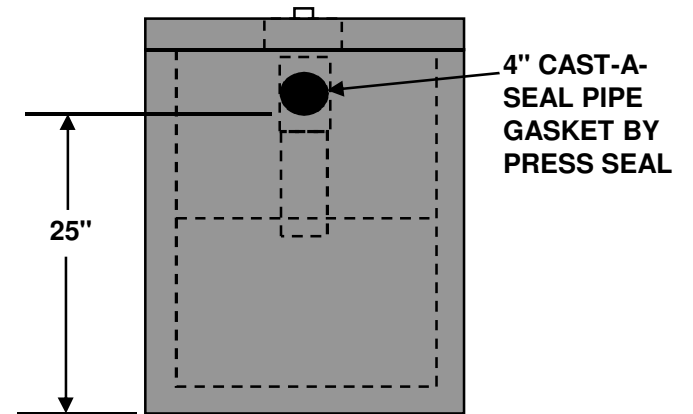

INLET  
 END VIEW